

# Technical specifications.

## BMW Z4.

### Z4 M40i Pure Impulse edition.



BMW Z4 M40i Pure Impulse edition		
<b>Body</b>		
No of doors/seats		2 / 2
Length/width/height (unladen)	mm	4324 / 1864 / 1303
Wheelbase	mm	2470
Track, front/rear	mm	1594 / 1589
Ground clearance	mm	114
Turning circle	m	11.0
Fuel tank capacity	approx. l	52
Engine oil <sup>1)</sup>	l	6.5
Weight, unladen, to DIN/EU	kg	1550 / 1625
Max load to DIN	kg	310
Max permissible weight	kg	1860
Max axle load, front/rear	kg	880 / 995
Max trailer load		
braked (12%)/unbraked	kg	- / -
Max roofload/max towbar download	kg	- / -
Luggage comp capacity	l	281
Air resistance	c <sub>d</sub> x A	0.31 x 2.07
<b>Power Unit</b>		
Config/No of cyls/valves		In-line / 6 / 4
Engine technology		BMW TwinPower Turbo technology: TwinScroll turbocharger, High Precision Injection, VALVETRONIC fully variable valve timing, Double-VANOS variable camshaft timing
Effective capacity	cc	2998
Stroke/bore	mm	94.6 / 82.0
Compression ratio	:1	11.0
Fuel		min. RON 91
Max output	kW/hp	250 / 340
at	rpm	5000 – 6500
Max torque	Nm	500
at	rpm	1600 – 4500
<b>Electrical System</b>		
Battery/installation	Ah/-	92 / luggage compartment
<b>Driving Dynamics and Safety</b>		
Suspension, front		Double-joint spring strut axle in lightweight aluminium-steel construction, hydraulically damped torque strut bearing
Suspension, rear		Five-link axle in lightweight aluminium-steel construction
Brakes, front		Vented disc brakes, with four-piston fixed callipers
Brakes, rear		Vented disc brakes, with single-piston floating callipers
Driving stability systems		Standard: DSC incl. ABS and DTC (Dynamic Traction Control), CBC (Cornering Brake Control), DBC (Dynamic Brake Control), Dry Braking function, Fading Compensation, Start-Off Assistant, Adaptive suspension, M Sport differential
Safety equipment		Standard: airbags for driver and front passenger, side airbags for driver and front passenger with combined head airbags, three-point inertia-reel seatbelts with belt tensioner and belt force limiter, crash sensors, rollover protection system, tyre pressure indicator
Steering		Electric Power Steering (EPS) with Servotronic function, variable sport steering
Steering ratio, overall	:1	15.1
Tyres, front/rear		255/35 ZR19 / 285/30 ZR20
Rims, front/rear		9J x 19 light-alloy / 10J x 20 light-alloy

**BMW Z4 M40i Pure Impulse edition**

**Transmission**

Type of transmission	Six-speed manual		
Gear ratios	I	:1	4.110
	II	:1	2.315
	III	:1	1.542
	IV	:1	1.179
	V	:1	1.000
	VI	:1	0.846
	R	:1	3.727
Final drive		:1	3.462

**Performance**

Power-to-weight ratio (DIN)	kg/kW	6.2
Output per litre	kW/l	83.4
Acceleration	0–100 km/h	s
in 5 <sup>th</sup> gear	80–120 km/h	s
Top speed	km/h	250

**BMW EfficientDynamics**

BMW EfficientDynamics standard features	Brake Energy Regeneration with recuperation display, Electric Power Steering, Auto Start Stop function, Optimum Shift Indicator, Proactive Driving Assistant, BMW EfficientLightweight, optimised aerodynamic attributes, active air flap control, on-demand operation of ancillary units, map-regulated oil pump, differential with optimised warm-up behaviour
---	--

**Fuel Consumption ECE**

Combined (WLTP)	l/100	8.7
Combined (NEDC)	l/100	–
CO <sub>2</sub> (WLTP)	g/km	197 – 195
CO <sub>2</sub> (NEDC)	g/km	–
Emission rating		Euro 6e

Specifications apply to ACEA markets/data relevant to homologation applies in part only to Germany (weight)

<sup>1)</sup> Oil change

Official fuel consumption, CO<sub>2</sub> emissions, electric power consumption and electric range figures were determined based on the prescribed measurement procedure in accordance with European Regulation (EC) 2007/715 in the version applicable. Where a range is shown, the WLTP figures take into account the impact of any optional extras.

Only official figures based on the WLTP procedure are available for new models that have been type tested since 01.01.2021. In addition, according to EU Regulation 2022/195, the NEDC values will no longer be included in the EC certificates of conformity as of 01.01.2023. Further information on the WLTP and NEDC measurement procedures can also be found at [www.bmw.de/wltp](http://www.bmw.de/wltp).

Further information on official fuel consumption figures and specific CO<sub>2</sub> emission values of new passenger cars is included in the following guideline: 'Leitfaden über den Kraftstoffverbrauch, die CO<sub>2</sub>-Emissionen und den Stromverbrauch neuer Personenkraftwagen' (Guide to the fuel economy, CO<sub>2</sub> emissions and electric power consumption of new passenger cars), which can be obtained free of charge from all dealerships, from Deutsche Automobil Treuhand GmbH (DAT), Hellmuth-Hirth-Str. 1, 73760 Ostfildern-Scharnhausen and at <https://www.dat.de/co2/>.

# BMW Z4. Z4 M40i.

<b>BMW Z4 M40i</b>		
<b>Body</b>		
No of doors/seats		2 / 2
Length/width/height (unladen)	mm	4324 / 1864 / 1303
Wheelbase	mm	2470
Track, front/rear	mm	1594 / 1589
Ground clearance	mm	114
Turning circle	m	11.0
Fuel tank capacity	approx. l	52
Engine oil <sup>1)</sup>	l	6.5
Weight, unladen, to DIN/EU	kg	1565 / 1640
Max load to DIN	kg	295
Max permissible weight	kg	1860
Max axle load, front/rear	kg	880 / 995
Max trailer load		
braked (12%)/unbraked	kg	- / -
Max roofload/max towbar download	kg	- / -
Luggage comp capacity	l	281
Air resistance	c <sub>d</sub> x A	0.31 x 2.07
<b>Power Unit</b>		
Config/No of cyls/valves		In-line / 6 / 4
Engine technology		BMW TwinPower Turbo technology: TwinScroll turbocharger, High Precision Injection, VALVETRONIC fully variable valve timing, Double-VANOS variable camshaft timing
Effective capacity	cc	2998
Stroke/bore	mm	94.6 / 82.0
Compression ratio	:1	11.0
Fuel		min. RON 91
Max output	kW/hp	250 / 340
at	rpm	5000 – 6500
Max torque	Nm	500
at	rpm	1600 – 4500
<b>Electrical System</b>		
Battery/installation	Ah/-	92 / luggage compartment
<b>Driving Dynamics and Safety</b>		
Suspension, front		Double-joint spring strut axle in lightweight aluminium-steel construction, hydraulically damped torque strut bearing
Suspension, rear		Five-link axle in lightweight aluminium-steel construction
Brakes, front		Vented disc brakes, with four-piston fixed callipers
Brakes, rear		Vented disc brakes, with single-piston floating callipers
Driving stability systems		Standard: DSC incl. ABS and DTC (Dynamic Traction Control), CBC (Cornering Brake Control), DBC (Dynamic Brake Control), Dry Braking function, Fading Compensation, Start-Off Assistant, Adaptive suspension, M Sport differential
Safety equipment		Standard: airbags for driver and front passenger, side airbags for driver and front passenger with combined head airbags, three-point inertia-reel seatbelts with belt tensioner and belt force limiter, crash sensors, rollover protection system, tyre pressure indicator
Steering		Electric Power Steering (EPS) with Servotronic function, variable sport steering
Steering ratio, overall	:1	15.1
Tyres, front/rear		255/40 ZR18 95Y / 275/40 ZR18 99Y
Rims, front/rear		9J x 18 light-alloy / 10J x 18 light-alloy

<b>BMW Z4 M40i</b>			
<b>Transmission</b>			
Type of transmission	Eight-speed Steptronic transmission		
Gear ratios	I	:1	5.250
	II	:1	3.360
	III	:1	2.172
	IV	:1	1.720
	V	:1	1.316
	VI	:1	1.000
	VII	:1	0.822
	VIII	:1	0.640
	R	:1	3.712
Final drive		:1	3.154
<b>Performance</b>			
Power-to-weight ratio (DIN)	kg/kW		6.3
Output per litre	kW/l		83.4
Acceleration 0–100 km/h	s		4.5
Top speed	km/h		250
<b>BMW EfficientDynamics</b>			
BMW EfficientDynamics standard features	Brake Energy Regeneration with recuperation display, Electric Power Steering, Auto Start Stop function, Optimum Shift Indicator, ECO PRO mode with coasting function, Proactive Driving Assistant, BMW EfficientLightweight, optimised aerodynamic attributes, active air flap control, on-demand operation of ancillary units, map-regulated oil pump, differential with optimised warm-up behaviour		
<b>Fuel Consumption ECE</b>			
Combined (WLTP)	l/100		8.0 – 7.8
Combined (NEDC)	l/100		–
CO <sub>2</sub> (WLTP)	g/km		181 – 175
CO <sub>2</sub> (NEDC)	g/km		–
Emission rating			Euro 6e

Specifications apply to ACEA markets/data relevant to homologation applies in part only to Germany (weight)

<sup>1)</sup> Oil change

Official fuel consumption, CO<sub>2</sub> emissions, electric power consumption and electric range figures were determined based on the prescribed measurement procedure in accordance with European Regulation (EC) 2007/715 in the version applicable. Where a range is shown, the WLTP figures take into account the impact of any optional extras.

Only official figures based on the WLTP procedure are available for new models that have been type tested since 01.01.2021. In addition, according to EU Regulation 2022/195, the NEDC values will no longer be included in the EC certificates of conformity as of 01.01.2023. Further information on the WLTP and NEDC measurement procedures can also be found at [www.bmw.de/wltp](http://www.bmw.de/wltp).

Further information on official fuel consumption figures and specific CO<sub>2</sub> emission values of new passenger cars is included in the following guideline: 'Leitfaden über den Kraftstoffverbrauch, die CO<sub>2</sub>-Emissionen und den Stromverbrauch neuer Personenkraftwagen' (Guide to the fuel economy, CO<sub>2</sub> emissions and electric power consumption of new passenger cars), which can be obtained free of charge from all dealerships, from Deutsche Automobil Treuhand GmbH (DAT), Hellmuth-Hirth-Str. 1, 73760 Ostfildern-Scharnhausen and at <https://www.dat.de/co2/>.

# BMW Z4. Z4 sDrive30i.

BMW Z4 sDrive30i		
<b>Body</b>		
No of doors/seats		2 / 2
Length/width/height (unladen)	mm	4324 / 1864 / 1304
Wheelbase	mm	2470
Track, front/rear	mm	1618 / 1613
Ground clearance	mm	117
Turning circle	m	11.0
Fuel tank capacity	approx. l	52
Engine oil <sup>1)</sup>	l	5.25
Weight, unladen, to DIN/EU	kg	1470 / 1545
Max load to DIN	kg	290
Max permissible weight	kg	1760
Max axle load, front/rear	kg	840 / 935
Max trailer load		
braked (12%)/unbraked	kg	- / -
Max roofload/max towbar download	kg	- / -
Luggage comp capacity	l	281
Air resistance	c <sub>d</sub> x A	0.31 x 2.07
<b>Power Unit</b>		
Config/No of cyls/valves		In-line / 4 / 4
Engine technology		BMW TwinPower Turbo technology: TwinScroll turbocharger, High Precision Injection, VALVETRONIC fully variable valve timing, Double-VANOS variable camshaft timing
Effective capacity	cc	1998
Stroke/bore	mm	94.6 / 82.0
Compression ratio	:1	10.2
Fuel		min. RON 91
Max output	kW/hp	190 / 258
at	rpm	5000 – 6500
Max torque	Nm	400
at	rpm	1550 – 4400
<b>Electrical System</b>		
Battery/installation	Ah/-	80 / luggage compartment
<b>Driving Dynamics and Safety</b>		
Suspension, front		Double-joint spring strut axle in lightweight aluminium-steel construction, hydraulically damped torque strut bearing
Suspension, rear		Five-link axle in lightweight aluminium-steel construction
Brakes, front		Vented disc brakes, with four-piston fixed callipers
Brakes, rear		Vented disc brakes, with single-piston floating callipers
Driving stability systems		Standard: DSC incl. ABS and DTC (Dynamic Traction Control), CBC (Cornering Brake Control), DBC (Dynamic Brake Control), Dry Braking function, Fading Compensation, Start-Off Assistant, M Sport suspension; optional: Adaptive suspension, M Sport differential
Safety equipment		Standard: airbags for driver and front passenger, side airbags for driver and front passenger with combined head airbags, three-point inertia-reel seatbelts with belt tensioner and belt force limiter, crash sensors, rollover protection system, tyre pressure indicator
Steering		Electric Power Steering (EPS) with Servotronic function, variable sport steering
Steering ratio, overall	:1	15.1
Tyres, front/rear		225/45 R18 95Y / 255/40 R18 99Y
Rims, front/rear		8J x 18 light-alloy / 9J x 18 light-alloy

<b>BMW Z4 sDrive30i</b>			
<b>Transmission</b>			
Type of transmission	Eight-speed Steptronic transmission		
Gear ratios	I	:1	5.250
	II	:1	3.360
	III	:1	2.172
	IV	:1	1.720
	V	:1	1.316
	VI	:1	1.000
	VII	:1	0.822
	VIII	:1	0.640
	R	:1	3.712
Final drive		:1	3.154
<b>Performance</b>			
Power-to-weight ratio (DIN)	kg/kW		7.7
Output per litre	kW/l		95.1
Acceleration 0–100 km/h	s		5.4
Top speed	km/h		250
<b>BMW EfficientDynamics</b>			
BMW EfficientDynamics standard features	Brake Energy Regeneration with recuperation display, Electric Power Steering, Auto Start Stop function, Optimum Shift Indicator, ECO PRO mode with coasting function, Proactive Driving Assistant, BMW EfficientLightweight, optimised aerodynamic attributes, active air flap control, on-demand operation of ancillary units, map-regulated oil pump, differential with optimised warm-up behaviour, tyres with reduced rolling resistance		
<b>Fuel Consumption ECE</b>			
Combined (WLTP)	l/100		7.4 – 7.0
Combined (NEDC)	l/100		–
CO <sub>2</sub> (WLTP)	g/km		167 – 159
CO <sub>2</sub> (NEDC)	g/km		–
Emission rating			Euro 6e

Specifications apply to ACEA markets/data relevant to homologation applies in part only to Germany (weight)

<sup>1)</sup> Oil change

Official fuel consumption, CO<sub>2</sub> emissions, electric power consumption and electric range figures were determined based on the prescribed measurement procedure in accordance with European Regulation (EC) 2007/715 in the version applicable. Where a range is shown, the WLTP figures take into account the impact of any optional extras.

Only official figures based on the WLTP procedure are available for new models that have been type tested since 01.01.2021. In addition, according to EU Regulation 2022/195, the NEDC values will no longer be included in the EC certificates of conformity as of 01.01.2023. Further information on the WLTP and NEDC measurement procedures can also be found at [www.bmw.de/wltp](http://www.bmw.de/wltp).

Further information on official fuel consumption figures and specific CO<sub>2</sub> emission values of new passenger cars is included in the following guideline: 'Leitfaden über den Kraftstoffverbrauch, die CO<sub>2</sub>-Emissionen und den Stromverbrauch neuer Personenkraftwagen' (Guide to the fuel economy, CO<sub>2</sub> emissions and electric power consumption of new passenger cars), which can be obtained free of charge from all dealerships, from Deutsche Automobil Treuhand GmbH (DAT), Hellmuth-Hirth-Str. 1, 73760 Ostfildern-Scharnhausen and at <https://www.dat.de/co2/>.

# BMW Z4. Z4 sDrive20i.

BMW Z4 sDrive20i		
<b>Body</b>		
No of doors/seats		2 / 2
Length/width/height (unladen)	mm	4324 / 1864 / 1304
Wheelbase	mm	2470
Track, front/rear	mm	1618 / 1613
Ground clearance	mm	117
Turning circle	m	11.0
Fuel tank capacity	approx. l	52
Engine oil <sup>1)</sup>	l	5.25
Weight, unladen, to DIN/EU	kg	1435 / 1510 (1450 / 1525)
Max load to DIN	kg	290 (290)
Max permissible weight	kg	1725 (1740)
Max axle load, front/rear	kg	830 / 935
Max trailer load		
braked (12%/unbraked)	kg	- / -
Max roofload/max towbar download	kg	- / -
Luggage comp capacity	l	281
Air resistance	c <sub>d</sub> x A	0.31 x 2.07
<b>Power Unit</b>		
Config/No of cyls/valves		In-line / 4 / 4
Engine technology		BMW TwinPower Turbo technology: TwinScroll turbocharger, High Precision Injection, VALVETRONIC fully variable valve timing, Double-VANOS variable camshaft timing
Effective capacity	cc	1998
Stroke/bore	mm	94.6 / 82.0
Compression ratio	:1	10.2
Fuel		min. RON 91
Max output	kW/hp	145 / 197
at	rpm	4500 – 6500
Max torque	Nm	320
at	rpm	1450 – 4200
<b>Electrical System</b>		
Battery/installation	Ah/-	80 / luggage compartment
<b>Driving Dynamics and Safety</b>		
Suspension, front		Double-joint spring strut axle in lightweight aluminium-steel construction, hydraulically damped torque strut bearing
Suspension, rear		Five-link axle in lightweight aluminium-steel construction
Brakes, front		Vented disc brakes, with single-piston floating callipers
Brakes, rear		Vented disc brakes, with single-piston floating callipers
Driving stability systems		Standard: DSC incl. ABS and DTC (Dynamic Traction Control), CBC (Cornering Brake Control), DBC (Dynamic Brake Control), Dry Braking function, Fading Compensation, Start-Off Assistant; optional: M Sport suspension, Adaptive suspension
Safety equipment		Standard: airbags for driver and front passenger, side airbags for driver and front passenger with combined head airbags, three-point inertia-reel seatbelts with belt tensioner and belt force limiter, crash sensors, rollover protection system, tyre pressure indicator
Steering		Electric Power Steering (EPS) with Servotronic function, variable sport steering
Steering ratio, overall	:1	15.1
Tyres, front/rear		225/45 R18 95Y / 255/40 R18 99Y
Rims, front/rear		8J x 18 light-alloy / 9J x 18 light-alloy

<b>BMW Z4 sDrive20i</b>			
<b>Transmission</b>			
Type of transmission	Six-speed manual (eight-speed Steptronic transmission)		
Gear ratios	I	:1	4.110 (5.250)
	II	:1	2.248 (3.360)
	III	:1	1.403 (2.172)
	IV	:1	1.000 (1.720)
	V	:1	0.786 (1.316)
	VI	:1	0.601 (1.000)
	VII	:1	– (0.822)
	VIII	:1	– (0.640)
	R	:1	3.727 (3.712)
Final drive		:1	3.636 (3.154)
<b>Performance</b>			
Power-to-weight ratio (DIN)	kg/kW		9.9 (10.0)
Output per litre	kW/l		72.6
Acceleration 0–100 km/h	s		6.8 (6.6)
in 5 <sup>th</sup> gear 80–120 km/h	s		7.5 (–)
Top speed	km/h		241 (240)
<b>BMW EfficientDynamics</b>			
BMW EfficientDynamics standard features	Brake Energy Regeneration with recuperation display, Electric Power Steering, Auto Start Stop function, Optimum Shift Indicator, ECO PRO mode with coasting function (with automatic transmission), Proactive Driving Assistant, BMW EfficientLightweight, optimised aerodynamic attributes, active air flap control, on-demand operation of ancillary units, map-regulated oil pump, differential with optimised warm-up behaviour, tyres with reduced rolling resistance		
<b>Fuel Consumption ECE</b>			
Combined (WLTP)	l/100		7.4 – 7.1 (7.3 – 6.9)
Combined (NEDC)	l/100		– (–)
CO <sub>2</sub> (WLTP)	g/km		167 – 159 (164 – 157)
CO <sub>2</sub> (NEDC)	g/km		– (–)
Emission rating			Euro 6e

Specifications apply to ACEA markets/data relevant to homologation applies in part only to Germany (weight)  
Figures in brackets apply to models with automatic transmission

<sup>1)</sup> Oil change

Official fuel consumption, CO<sub>2</sub> emissions, electric power consumption and electric range figures were determined based on the prescribed measurement procedure in accordance with European Regulation (EC) 2007/715 in the version applicable. Where a range is shown, the WLTP figures take into account the impact of any optional extras.

Only official figures based on the WLTP procedure are available for new models that have been type tested since 01.01.2021. In addition, according to EU Regulation 2022/195, the NEDC values will no longer be included in the EC certificates of conformity as of 01.01.2023. Further information on the WLTP and NEDC measurement procedures can also be found at [www.bmw.de/wltp](http://www.bmw.de/wltp).

Further information on official fuel consumption figures and specific CO<sub>2</sub> emission values of new passenger cars is included in the following guideline: 'Leitfaden über den Kraftstoffverbrauch, die CO<sub>2</sub>-Emissionen und den Stromverbrauch neuer Personenkraftwagen' (Guide to the fuel economy, CO<sub>2</sub> emissions and electric power consumption of new passenger cars), which can be obtained free of charge from all dealerships, from Deutsche Automobil Treuhand GmbH (DAT), Hellmuth-Hirth-Str. 1, 73760 Ostfildern-Scharnhausen and at <https://www.dat.de/co2/>.



# Exterior and interior dimensions. BMW Z4. Z4 M40i.

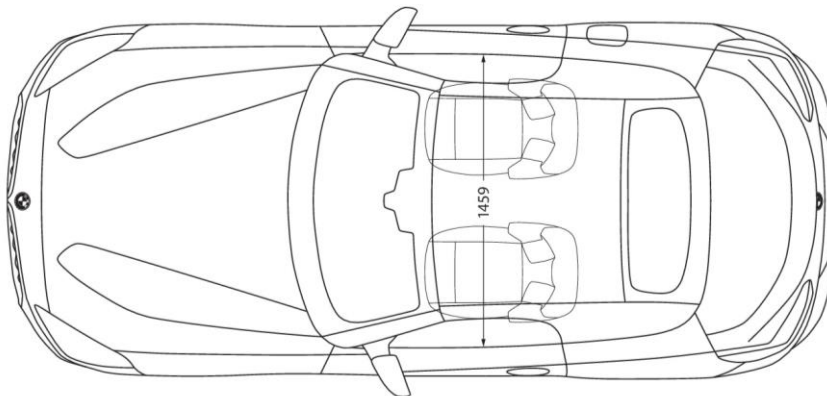
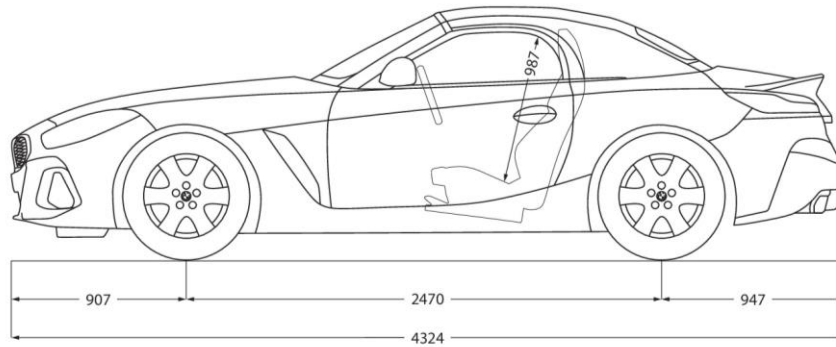
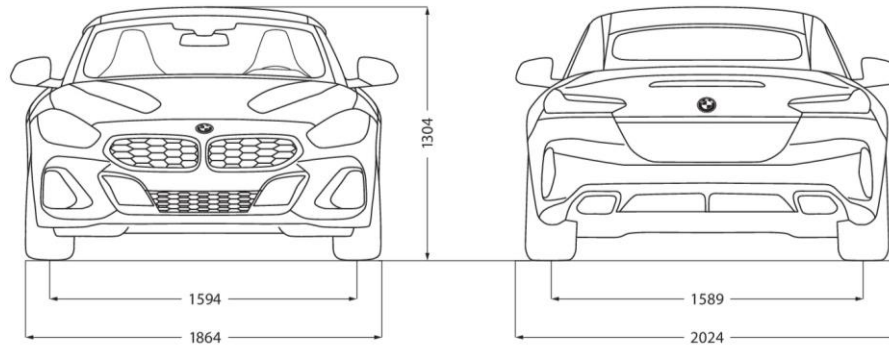

The dimensions in the technical drawing are in millimetres and may vary depending on the model and the optional equipment.

# BMW Z4. Z4 sDrive30i, Z4 sDrive20i.

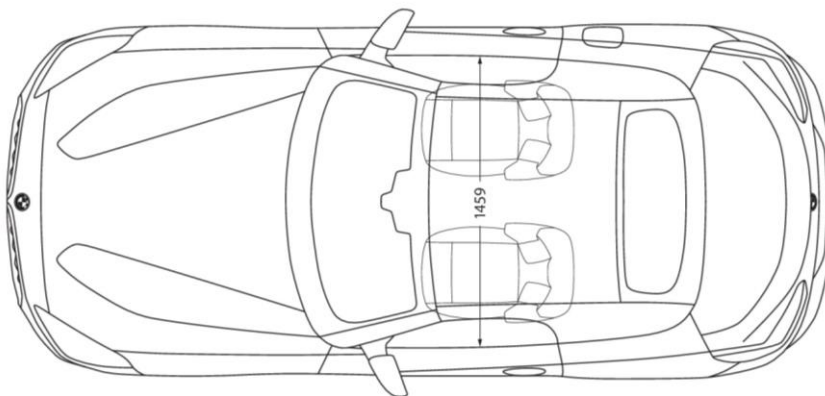
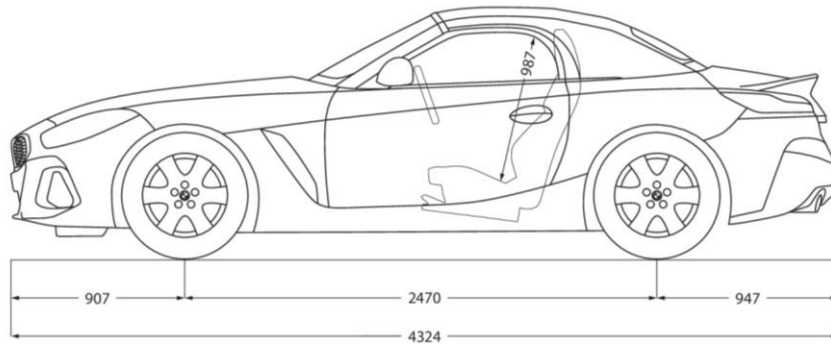
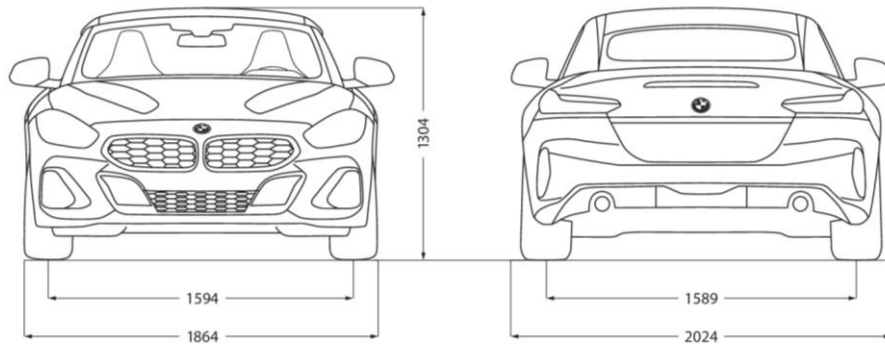

The dimensions in the technical drawing are in millimetres and may vary depending on the model and the optional equipment.